



BMS

ULTIMATE BUGDEFENCE MOSQUITO SYSTEM

- Economical and dependable
- Attractive integrated controller design
- Weather and corrosion resistant
- 3 function extended range remote control
- Tamper Proof - Lockable cabinet



BMS SYSTEM offers the most advanced controller in the industry today. With enhanced programming capabilities, excellent reliability and attractive design all at an affordable price. Available in both Digital and Analog.

BMS System - The ultimate in mosquito control for your home or business

The BMS has been designed and manufactured by Bug DeFence to ensure that we could deliver the industries most advanced, most reliable mosquito misting system all at an extremely affordable price.

The BMS is available with either an analog or digital controller (as shown below). While both offer the same Bug DeFence quality, dependability and variable run times, the BMS digital provides advanced programming and diagnostics for enhanced functionality, precise application and reliability.

Features of the BMS System

- Integrated Controller Design - pump and programmable controller in one clean polished system
- Surge protection
- Advanced Programming Capabilities - Event Timer, Repeat Cycle, Everyday, Individual Day, Weekday/Weekend *
- Digital Display with Touch Pad Programming and Indicator Lights for Accessories - Rain, Wind, Tank Level, Auto Run, Alarm Pump, Tank Mixer *
- Adaptive Microprocessor with Real Time Clock *
- Internal Battery back up *
- Password protection *
- Data Collection Capabilities: Runtime, Pump Hours, Daily Peak Temperature, Daily Peak Current *
- Board mounted RF (radio frequency) receiver - extended range

* Available on digital controller only

BMS Digital System



BMS Analog System



Ideal For:

Patios
Tennis Courts
Greenhouses
Resorts/Hotels
Shopping Centers

Gazebos
Rockscapes
Barns
Loading Docks
Factories

Pool Areas
Landscapes
Restaurants
Nurseries
Warehouses

Standard Install Configuration

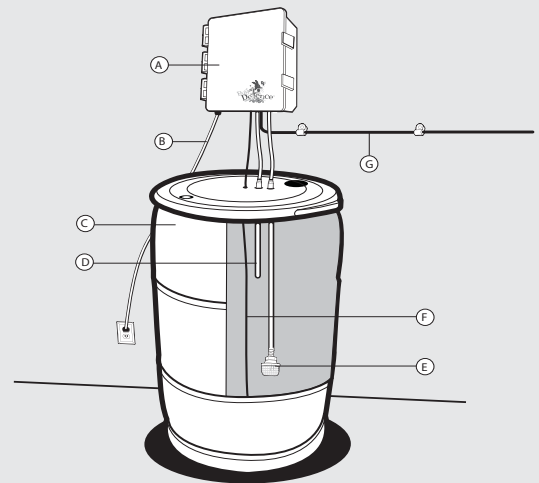

PART	DESCRIPTION
A	BMS Controller
B	Power Cord
C	55 Gallon Drum
D	Return Line
E	Strainer
F	Tank Level Sensor
G	Discharge Line

Optional Accessories for the BMS:



3-function remote



Rain Sensor



Wind Sensor

Interested in a green alternative?



Inquire about our proprietary Green Bug DeFence repellent.



HOUSTON OFFICE
10770 Moss Ridge Rd.,
Houston, TX 77043
(713) 895.0444
sales@bugdefence.com
TPCL#12519

SOUTH FLORIDA OFFICE
4081 SW 47th Avenue, Suite 16
Davie, FL 33314
(954) 316.1633
floridasales@bugdefence.com
FPCL#JE115343

ISO 9001:2008
CERTIFIED

Licensed and regulated by the structural pest control act. Department of agriculture, Texas, Florida.

REV053110